

INSTRUCTION MANUAL

FOR

SALE PRICE
\$ 3 00



RUGER®

Model 77/22® and Model 77/22® Magnum

BOLT ACTION RIFLE BLUED AND STAINLESS STEEL

The rifle shown below is the model 77/22S. It comes with a gold bead front sight and an adjustable rear sight, but it does *not* come with scope rings. The model 77/22R (not illustrated) does *not* have open sights on the barrel, but it does come with a set of Ruger scope rings.



**READ THE INSTRUCTIONS AND WARNINGS
IN THIS MANUAL CAREFULLY
BEFORE USING THIS FIREARM**

**THIS INSTRUCTION MANUAL SHOULD ALWAYS ACCOMPANY THIS FIREARM
AND BE TRANSFERRED WITH IT UPON CHANGE OF OWNERSHIP,
OR WHEN THE FIREARM IS LOANED OR PRESENTED TO ANOTHER PERSON.**

**STURM, RUGER and Company, Inc.
Southport, Connecticut 06490 U.S.A.**

**ALL RUGER FIREARMS ARE DESIGNED AND MANUFACTURED
IN RUGER FACTORIES IN THE UNITED STATES OF AMERICA**

**KJ/6-90
R3**

FIREARMS SAFETY—YOUR RESPONSIBILITY

SAFETY MUST BE THE FIRST AND CONSTANT CONSIDERATION OF EVERY PERSON WHO HANDLES FIREARMS AND AMMUNITION.

This Instruction Manual is designed to assist you in learning how to use and care for your rifle properly.

Only when you are certain you fully understand the Manual and can properly carry out its instructions should you practice loading, unloading, etc. with live ammunition.

If you have any doubts about your ability to handle or use a particular type of gun safely, then you should seek supervised instruction.

Such personalized instruction is often available from gun dealers, gun clubs or police departments. If none of these sources can help you, write to the National Rifle Association, Washington D.C. 20036. They will assist you.

The person with a gun in his possession has a full-time job. He cannot guess; he cannot forget. He must know how to use his firearm safely. *Do not use any firearm without having a complete understanding of its particular characteristics and safe use.* Remember: There is no such thing as a foolproof gun.

TABLE OF CONTENTS

	Page
General Information and Mechanical Characteristics	3
Ammunition	4
The Safety and its Operation	5
To Load and Fire	6 & 7
To Unload Rifle and Magazine	8
Avoiding Malfunctions ("Jams")	8
To Clear a Malfunction ("Jam")	9
Sight Adjustment and Attaching Scope Rings	10 & 11
Magazine Inspection and Care	10
Basic Disassembly and Reassembly	11-14
Care and Cleaning	14
Regarding Accuracy	14
Maintenance of Stainless Steel Rifles	15
Service and Parts Policy	16
Warranty Information	20
Parts List and Prices	17 & 19
The Basic Rules of Safe Firearms Handling	19 & 20

WARNINGS OF GREAT IMPORTANCE ARE FOUND ON THE FOLLOWING PAGES:

Alteration	2	Firing	7
Ammunition	4	Unloading	8
Bolt Obstructions	4	Malfunction	9
Loading	6	Lubrication	15
Handling	6	Parts Purchasers	16

Other Cautions and Warnings Appear Throughout the Manual

ALTERATION WARNING

Sturm, Ruger & Company, Inc. will not be responsible for *any* alteration of *any* part of this firearm after it leaves our control, or for the addition or substitution of parts or accessories not manufactured by Sturm, Ruger & Company, Inc. This product was designed to function properly *in its original condition*. Any changes made in this product are specifically contrary to our instructions and we expressly do *not* authorize any changes to be made after manufacture. *Do not jeopardize your safety or the safety of others by making modifications to your firearm.*

"RUGER" and "77/22" are U.S. registered trademarks.
Entire contents copyright 1990 by Sturm, Ruger & Company, Inc.

FIREARMS ARE DANGEROUS WEAPONS—READ THE INSTRUCTIONS AND WARNINGS IN THIS MANUAL THOROUGHLY AND CAREFULLY BEFORE USING THIS FIREARM

THE RUGER MODEL 77/22 RIFLE

Caliber .22 Long Rifle & Caliber .22 WMR

GENERAL INFORMATION AND MECHANICAL CHARACTERISTICS

The Ruger model 77/22^R is a bolt action, magazine fed, repeating rifle. The capacity of the rotary magazine is ten 22 Long Rifle cartridges (or 9 .22 WMR cartridges in the 77/22 magnum *only*).

The receiver on all versions of the model 77/22 rifle incorporates integral scope mount bases (see illustration below). The model 77/22R comes with a set of two Ruger 1" steel scope rings. The R model does *not* have open sights. The model 77/22S comes with open sights — a gold bead front sight and a folding leaf rear sight which is adjustable for elevation and windage. The S model does *not* come with a set of scope rings. The 77/22RS is equipped with both. The K77/22 R & RS models come in stainless steel and have synthetic stocks with integral trigger guard assemblies.

Other notable features of the Ruger model 77/22 rifle include: A three-position safety, two bolt lugs locking into matching channels in the receiver, a fast lock-time trigger mechanism (non-adjustable), a flush positioned bolt stop (bolt release), an American walnut stock, hand checkered, with a polyurethane finish, Nylon butt-plate and studs to which sling swivels can be attached.

Disassembly of the rifle to its major components is readily accomplished by removal of two screws. The bolt assembly can be quickly disassembled for cleaning.

All mechanical components are made of heat-treated chrome-molybdenum or stainless steel, with music wire coil springs throughout the mechanism.

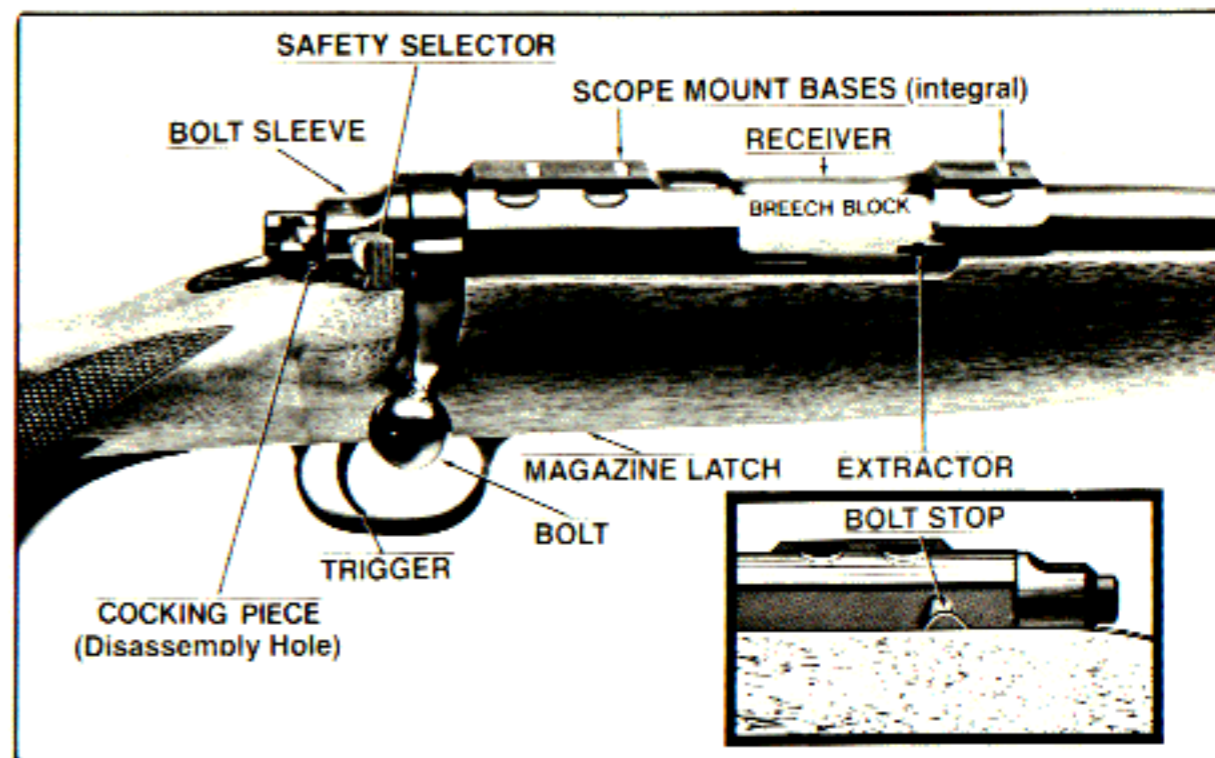

Figure 1. Components frequently referred to are identified. In this illustration the cocking piece is shown cocked (protruding from the rear of the bolt sleeve) revealing the disassembly hole in the lower portion of the cocking piece. The bolt stop (on the left side of the receiver) permits the bolt to be withdrawn simply by pressing down lightly with the thumbnail. The safety selector (shown in the "Fire" position) should be in the "Load-Unload" position when the bolt is being removed or being installed.

AMMUNITION

The Ruger 77/22 is chambered for, and designed to properly function as a repeating rifle with the 22 caliber Long Rifle rim fire cartridge, standard, high velocity, or hyper-velocity, manufactured to industry standards.

The 22 Short, 22 Long and 22 SHOT cartridges can be fired in the model 77/22 rifle, but such cartridges must be introduced by hand directly into the chamber. It should be noted that extensive use of the 22 Short cartridge can cause a 'ring' to be cut in the chamber which may interfere with the extraction of Long Rifle cartridges.

The Ruger Model 77/22[®] magnum is chambered for the .22 Winchester magnum rimfire cartridge *only*, both jacketed and hollow point. Do not use any other .22 caliber ammunition in this rifle, as burst cases and the release of hot powder gases can result.

WARNING: Do not attempt to load 22 Short, 22 Long, 22 SHOT or any other type of 22 caliber cartridge (other than the 22 Long Rifle) *into the magazine* of the 77/22 rifle. The use of other than Long Rifle cartridges in the magazine can cause potentially dangerous jams and malfunctions resulting in damage to the firearm and injury to the shooter and other persons. Take care to use the correct cartridges.

WARNING: Some types of Long Rifle cartridges have blunt-nose or sharp-shoulder bullets which can interfere with smooth and reliable feeding from magazine to chamber. Such cartridges should *not* be used because they may discharge before being fully chambered and thereby possibly injure the shooter and those nearby. The shooter must be alert to this potentially dangerous situation and should at once discontinue the use of any cartridge which appears to be the cause of feeding problems or jamming. **Never use explosive-bullet cartridges.**

DANGER—AMMUNITION WARNING

Firearms may be damaged, and death or serious injury to the shooter or other persons may result, from any condition which contributes to the generation of excessive pressure, or the uncontrolled release of gas, within a firearm. The foregoing adverse conditions can be caused by *bore or chamber obstruction, propellant powder overloads, or by defective, incorrect, or improperly loaded and assembled cartridge components.* The relatively soft and thin metal used in .22 caliber rimfire cartridges makes burst caseheads a not uncommon occurrence in firearms of this caliber, therefore, *always* wear shooting glasses and hearing protectors.

It is extremely dangerous to use a cartridge whose pressure is greater than that developed by cartridges loaded to Industry Standards. Even the strongest firearm can be blown up as a result of excessive pressure.

AMMUNITION (CARTRIDGES) NOTICE

WE SPECIFICALLY DISCLAIM RESPONSIBILITY FOR ANY DAMAGE OR INJURY WHATSOEVER OCCURRING IN CONNECTION WITH, OR AS THE RESULT OF, THE USE IN RUGER FIREARMS OF FAULTY, OR NON-STANDARD, OR "REMANUFACTURED" OR HAND LOADED (RELOADED) AMMUNITION, OR OF CARTRIDGES OTHER THAN THOSE FOR WHICH THE FIREARM WAS ORIGINALLY CHAMBERED.

BORE OBSTRUCTIONS WARNING

Before loading or firing the rifle, examine the bore to be certain it is clear and unobstructed. *Firing a gun with any obstruction in the bore—even a heavy coating of oil, or drops of water—may result in damage to the gun and injury to the shooter and other persons nearby.*

A misfire or unusual report (sound) upon firing is always a signal to cease firing and immediately examine the chamber and bore. If there is any obstruction—full or partial—clear the obstruction with a cleaning rod and bore brush before firing the rifle.

THE SAFETY AND ITS OPERATION

The 77/22 rifle has a three position safety. The safety selector (J-38) is located at the right of the bolt sleeve (J-17).

The safety selector can be moved from the "Fire" position to its two other positions ("Load-Unload" and "Safe") only when the firing pin is cocked. Fully raising the bolt handle cocks the firing pin.

The bolt handle can be raised and lowered only when the safety selector is in either the "Fire" or the "Load-Unload" position. When the safety selector is in the "Safe" position, the bolt handle is locked in the closed (full down) position. The bolt handle must be closed fully before the safety selector is moved to the "Safe" position.

Practice (with an unloaded rifle) moving the safety selector to the three positions until you know by feel and by sight the position of the safety selector for the three modes—"Fire", "Load-Unload", and "Safe". **WARNING:** When manipulating the safety selector, **DO NOT HAVE ANY FINGER INSIDE THE TRIGGER GUARD!** When the safety selector is in the "Fire" position and the trigger is pulled, the rifle will fire.

The safety selector should always be in the "Safe" position except when the gun user is actually firing the rifle. The safety selector should unfailingly be moved to the "Safe" position when the gun user ceases firing.

The safety selector is held in each of its three positions by a plunger that is under spring tension. Therefore, the gun user should frequently check the position of the safety selector to be certain it has not been inadvertently moved. If the safety selector seems to move too easily, or if the safety selector does not seem firmly positioned in any of its three positions, the rifle should be discontinued from use and returned to the Newport Service Department for repair.

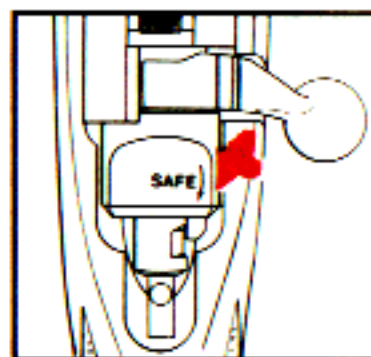

Figure 2. Safety selector in "FIRE" position. Note that the safety selector is in its full forward position. The safety selector should be moved to this position only when the gun user is actually going to fire the rifle. When a firearm safety is in the *fire* position, it is referred to as being "off". (When a firearm safety is in the *safe* position, it is referred to as being "on".)

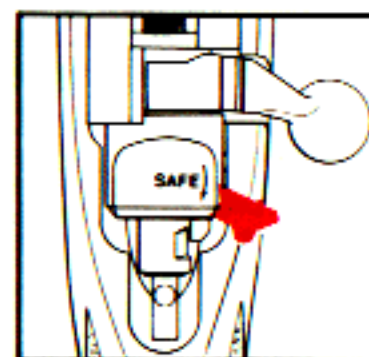

Figure 3. Safety selector in "LOAD-UNLOAD" position. The safety selector should be in this position when the bolt is being cycled to chamber a cartridge, or to extract a live round. Just as soon as a cartridge is chambered, the safety selector should be moved to the "SAFE" position unless the rifle is to be fired immediately.

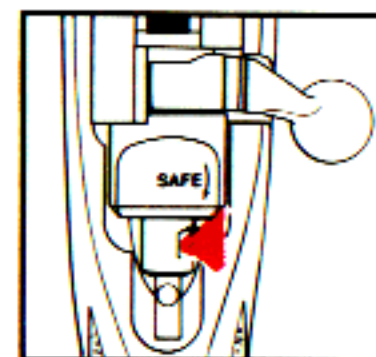

Figure 4. Safety selector in "SAFE" position. The selector is at its full rearward position and the tongue portion of the safety selector is fully nested in the groove in the cocking piece. When the safety selector is in this position, the bolt handle cannot be raised. The curved arrow on the bolt sleeve indicates the direction and motion of the safety selector to bring it to the "SAFE" position.

WARNING: THE USER SHOULD NEVER DEPEND ON A SAFETY MECHANISM OR ANY OTHER MECHANICAL DEVICE TO JUSTIFY CARELESS HANDLING OR PERMITTING THE RIFLE TO POINT IN AN UNSAFE DIRECTION.

LOADING WARNING

The safety selector should be in the "Safe" position at all times except when the rifle is pointed at the target and the shooter is ready to fire.

If a cartridge does not chamber readily, check the bore and chamber to be certain they are free of obstructions. If the bore and chamber are clear, and the cartridge still does not chamber, check to be certain the cartridge is of the proper caliber and style. (See AMMUNITION WARNING.) Do not apply unusual pressure to the bolt handle in an attempt to chamber a cartridge that does not readily chamber. If the bolt does not close under normal hand closing pressure do not force it! A 22 caliber rim fire cartridge discharged outside of the chamber by the impact of the closing breech mechanism can result in possible serious injury to the shooter and those nearby. **WARNING: Always wear shooting glasses and hearing protectors!**

HANDLING WARNING

Do not load the model 77/22 until you are ready to use it, and unload it *immediately* when you have completed shooting.

Do not chamber a cartridge until you are in the immediate area where you plan to shoot. Put the safety selector in the "Load-Unload" position before chambering a cartridge, and never carry the rifle loaded with the safety selector in the Fire position.

The 77/22 should be carried and handled so it will not be dropped or struck. With the safety selector in the "Fire" position, the rifle is in the ready-to-fire mode. Therefore, as in any firearm, any blow or jar which is of sufficient force to actuate components of the firing mechanism may cause a chambered cartridge to discharge. Such a discharge can occur with or without the trigger being directly struck or touched.

Never rest a loaded rifle against any object (wall, fence, vehicle, tree, etc.) because there is always the possibility that the rifle will be jarred or slide from its position and fall with sufficient force to discharge.

Never store a firearm in such a manner that it may be pulled from a shelf or 'hidden place' as some other item is moved.

The shooter should always be alert to the possibility of accidental discharge regardless of the position of the safety. The only safe rifle is one in which the bolt is open and the magazine and chamber are empty.

TO LOAD AND FIRE

Practice the important aspects of gun handling described below (with an unloaded rifle) until you can perform each of the steps with skill and confidence. But *before* loading the rifle, please first read *completely thru* this manual.

Before attempting to load or unload the rifle, be certain the muzzle is pointing in a safe direction.

(The following procedure assumes that the user has received a new rifle with the bolt not in the rifle, but the magazine is in the rifle.)

1. Remove the magazine from the rifle (see Figure 5).
2. Position the safety selector in the "Load-Unload" position (see Figure 3).
3. Make certain the bolt is ready to be inserted in the receiver. If there is any doubt, see numbered paragraph 7 (To Assemble the Bolt) in the Reassembly section of this manual.
4. Insert the bolt in the receiver, closing the bolt handle fully down.
5. Move the safety selector (J-38) to the "Safe" position. This will also lock the bolt closed (see Figure 4).

6. Load the magazine with the cartridges (see Figure 6)
7. Insert magazine into the magazine well of the rifle, bullet end of the cartridges in the direction of the barrel muzzle. (The magazine cannot be seated if it is reversed.)
8. Assuming the rifle is now to be fired, move the safety selector to the "Load-Unload" position.
9. Raise the bolt handle, draw the bolt fully to the rear, then smoothly push the bolt forward so that a cartridge is stripped from the magazine and chambered. (Note: If the cartridge does not readily strip from the magazine, or if the cartridge tends to jam while being chambered, discontinue the loading procedure. Extract and eject the 'problem' cartridge and remove the loaded magazine from the rifle. Then, read the Ammunition and the Magazine Inspection and Care sections of this manual.)
10. Unless the rifle is to be immediately fired, move the safety selector to the "Safe" position. (The rifle is now fully loaded.)
WARNING: DO NOT TOUCH THE TRIGGER UNTIL YOU ARE ACTUALLY READY TO FIRE THE RIFLE.
11. To Fire the Rifle: Move the safety selector to the "Fire" position (see Figure 2), and pull (squeeze) the trigger. A cartridge will be discharged. Always be certain that you know where the bullet will strike when you fire the rifle. (See Handling Warning in this manual.) Never allow the thumb to touch the cocking piece as it can be pinched when the striker moves forward.
12. After the chambered cartridge has been fired, the bolt handle is raised and the bolt is drawn to the rear in a firm, smooth stroke. This will extract and eject the fired cartridge case. To chamber another cartridge, repeat the procedure detailed directly above.
WARNING: Remember that each time a cartridge is fired and a new one is chambered, the safety selector is in the "Fire" position. Therefore, if the rifle is not going to be discharged immediately after the cartridge is chambered, move the safety selector to the "Safe" position.

Figure 5. The safety selector should be in the "Load-Unload" position or the "Safe" position when the magazine is being removed or inserted. When the forward section of the magazine latch is pushed in (pivoted upward), the magazine is released. One way of removing the magazine is to cradle the rifle in the left hand with the palm under—but not against—the magazine. Use the right forefinger to fully depress the magazine latch and the magazine will drop free. Another way (illustrated) is to depress the latch with the thumb and at the same time grasp the magazine between the thumb and forefinger and draw it out of the gun.

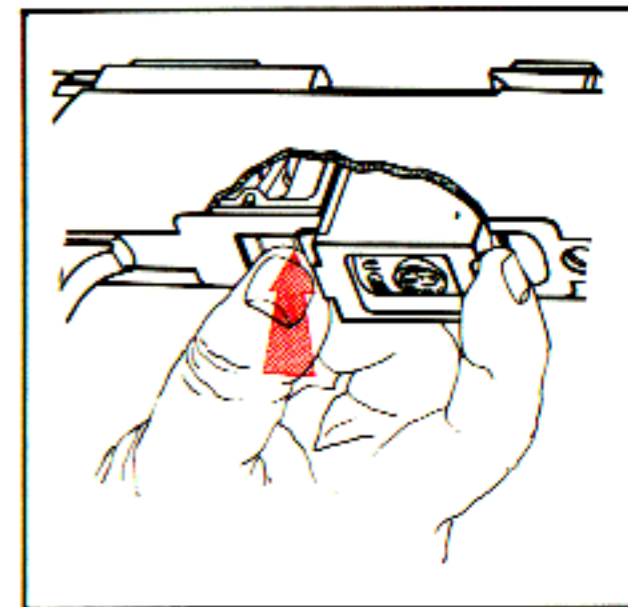

FIRING WARNING

When firing the model 77/22 be sure that bystanders are well clear of the shooter and standing a safe distance to the rear. Empty cartridge cases can be ejected from the rifle to the right with some velocity and could cause injury to any person who is standing too closely alongside the shooter. Shooters who fire the rifle from their left shoulder should be particularly cautious concerning ejected cartridge cases and the rear end of the bolt as it is drawn rearward. All shooters should wear suitable shooting glasses when firing any type of firearm.

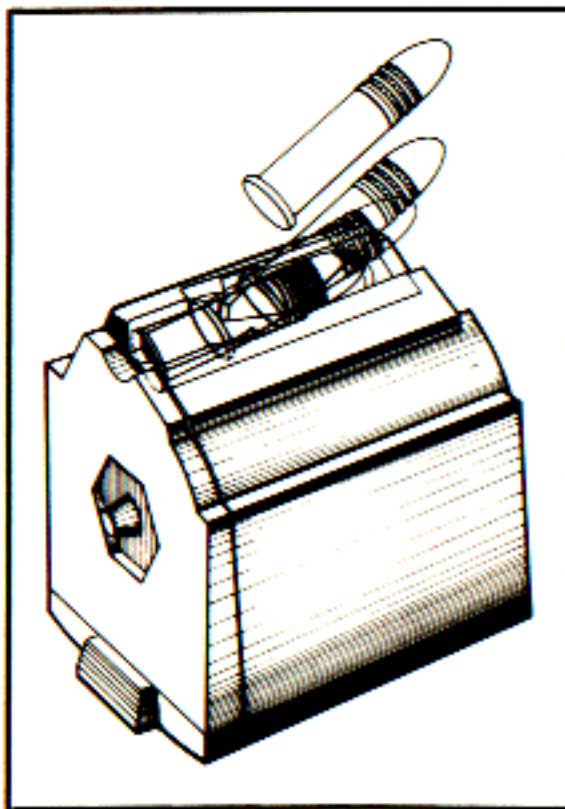

Figure 6. To load the magazine, grasp the forward section of a cartridge between thumb and forefinger and press the rim of the cartridge against the magazine rotor at the widest section of the magazine throat until the cartridge enters far enough to be pushed to the rear end of the magazine. With the first cartridge in place, each succeeding cartridge is pressed against the body of the top cartridge and slid to the rear of the magazine until a maximum of ten cartridges are in the magazine. The Ruger 77/22 rifle is designed to function properly only with the Ruger 10-shot rotary magazine (Part JX-1) loaded with 22 Long Rifle cartridges of the correct type.

The magazine must at all times be in good condition or malfunctions can occur. Please carefully read the sections in this manual on "Magazine Inspection and Care" and the section and Warning on Malfunctions.

NOTE: The Ruger 10/22 magazine (BX-1) will fit in the model 77/22 rifle, but the bottom section of the 10/22 magazine will not be flush with the trigger guard assembly of the 77/22. The 9 shot Ruger 77/22 magnum magazine is not interchangeable with any other magazine.

TO UNLOAD RIFLE AND MAGAZINE

(Rifle Must be Pointing in a Safe Direction)

If it is desired to discontinue shooting before all of the cartridges in the magazine and the chamber have been fired, proceed as follows:

1. Move the safety selector to the "Load-Unload" position.
2. Remove the magazine (see Figure 5).
3. Open the bolt carefully so the extracted live cartridge is not ejected forcibly.
4. Inspect the chamber to be certain the cartridge *has been* extracted.
5. Close the bolt fully.
6. Move the safety selector to the "Fire" position and *with the rifle pointing in a safe direction*, pull the trigger.
7. If necessary, cartridges can be removed from the magazine by simply pushing them lightly downward and forward with the thumb or forefinger. But, a better and safer procedure is to place the rubber eraser end of a pencil against the rim of the top cartridge and press lightly downward while pushing forward. **WARNING:** Do not use a loaded cartridge as a 'tool' to strip cartridges from the magazine.

UNLOADING WARNING

So the rifle can be used as a single loader for training or if the magazine is lost, removing the magazine from the rifle does *not* prevent the rifle from being fired! When there is a cartridge in the chamber, and the safety selector is in the "Fire" position, the cartridge will discharge if the trigger is pulled. It is absolutely essential for the user of a rifle to know how to *completely* unload it. "Completely" means *first* removing the magazine and *then* removing a chambered cartridge. The safety selector should always be in the "Load-Unload" position when the rifle is being unloaded. See "The Safety and Its Operation" section of this manual.

AVOIDING MALFUNCTIONS ("JAMS")

Firearms of all makes and types are susceptible to occasional malfunctioning due to a cartridge not feeding from the magazine to the chamber, or due to a cartridge or fired case not being extracted and ejected.

To minimize the possibility of such occurrences the gun user should:

— Use ammunition of the correct caliber and type which is loaded to Industry Specifications. Do not use cartridges that are deformed, or cartridges that have been once used in your 77/22 or any other firearm and gave trouble.

— Clean and lubricate the gun in accordance with the instructions in this Manual.

— Learn to correctly operate the bolt and how to properly load and empty the chamber and magazine.

— If the mechanism shows signs of not functioning correctly, or if a part is damaged or broken—don't use the rifle. Have it inspected, and repaired.*

A live cartridge should never be ejected, or dropped onto a hard surface that might forcibly contact the primer and fire the cartridge. Eject live cartridges onto a soft surface.

MALFUNCTION WARNING

The .22 rimfire cartridge has its sensitive priming compound distributed around the inside of its rim. It is fired by the impacting of the firing pin against the relatively soft cartridge case, which detonates the priming compound. *Any* crushing of the rim can cause a rimfire cartridge to be 'discharged' before it is chambered if the rim of the cartridge receives a sharp blow from *any* source. Accordingly, the user of a firearm chambered for a rimfire cartridge must regard any jam or feeding problem as a signal to immediately stop using the gun until it can be determined what is wrong.

If a cartridge hangs up, jams, or binds when being hand chambered or when being fed from the magazine into the chamber, *do not attempt to force it into the chamber by pushing or striking the bolt handle.*

Most failures of a cartridge to feed or to chamber are caused by use of a damaged magazine, improper loading of the magazine or ammunition that is of the incorrect type, or is defective.

Whatever the cause, the gun user must, above all, recognize that rimfire cartridge jams can result in the very potentially dangerous situation of a cartridge discharging before it is chambered. If this occurs, the cartridge case will rupture and its fragments will fly out of the gun with sufficient force to cause injury. *Always wear shooting glasses and hearing protectors!*

TO CLEAR A MALFUNCTION ("JAM")

(Rifle Must be Pointing in a Safe Direction)

If a jam occurs, immediately put the safety selector in the Load-Unload position and be certain the muzzle of the rifle is at all times pointing in a safe direction.

Then study the situation to determine the nature of the jam, and how best to clear it.

— If a cartridge or fired case is caught between the bolt and the barrel, or against a cartridge that is in the chamber, first remove the magazine. Then retract the bolt fully and remove the jammed cartridge or case.

— When attempting to extract a cartridge that is 'stuck' in the chamber, do not use any type of tool that is likely to act as a 'firing pin' and discharge the cartridge should the tool impact on the primer.

— After clearing a jam, inspect the gun mechanism to determine if dirt might be the cause of the problem. Excess lubricant or grease can cause cartridges to feed sluggishly or to fail to extract. An accumulation of grease or dirt on the face of the breech block, under the extractor or cartridge support, in the chamber or in the magazine can contribute to cartridge feeding problems. (See section on Magazine Inspection and Care.)

— After clearing a jam, inspect all cartridges that have been removed from the gun. Safely dispose of any cartridges which are in any way damaged.

— If it appears that the gun and magazine are not at fault and that the jam was caused by the type of cartridge being used, then try another type.

— If the above procedures do not result in a smooth and reliable feeding firearm,

* For regular repairs we recommend that Ruger guns be returned to the factory. However, if a gun has a cartridge in it which cannot be removed, then it is a violation of Federal Regulations to ship that loaded gun whether it be by U.S. Mail or by common carrier.

don't use the gun until it feeds cartridge smoothly and reliably. The model 77/22 can be returned directly to our Newport Service Department for repair. See the "Service and Parts Policy" section of this manual for packing and shipping information.

WARNING: Form the habit of examining fired cartridge cases from time to time. If fired cases have split, blown or bulged heads or show splits on any part of the case, the rifle should be promptly returned to the factory.

ATTACHING RUGER SCOPE RINGS

Each Ruger telescope ring is a mated assembly of a top and a base. Do not mix the parts of the two ring assemblies as they are not interchangeable.

On the underside of each mounting ring assembly there is an integral lug, located off center with respect to the front and back sides of the mount. The lug is nearer to the front surface. By reference to the lug, the mounting ring can be correctly assembled with the front of the ring toward the muzzle of the rifle.

Disassemble one ring and reassemble over the scope body between the turret and the eyepiece.

Install the four top screws. Do not tighten.

Disassemble the other ring and install it on the forward section of the scope tube with the lug forwardly also. Install the four top screws. Again, do not tighten.

Assemble the rings to the receiver with the lugs engaging the recesses in the top surface of the receiver. Tighten the clamp nuts so that the rings are locked to the semi-circular cuts on the sides of the receiver. Rotate the scope until cross-hairs are aligned properly, and slide scope to desired eye relief.

Then tighten the eight top screws each a bit at a time to grip the scope body. Sight in according to the directions with your scope.

SIGHT ADJUSTMENT (FOR RIFLES EQUIPPED WITH OPEN SIGHTS)

The folding leaf rear sight is adjustable for elevation. The slide must be moved one graduation to change the point of impact by approximately one inch at 25 yards. Shooting to determine the slide setting for 'zero' at a particular distance should be done from a bench rest and over a measured distance. Use only a small screwdriver with a blade tip that *exactly* fits the screw-head. Loosen the screws only slightly so the slide doesn't move too freely. Move the slide in the direction you want the point of impact of the bullet to move. When the slide is positioned at the desired height, carefully tighten both screws.

Lateral (windage) adjustment is made by 'drifting' the sight base in its slot. Place a short brass rod against the sight base (and only the base) and tap the sight in the direction you wish to move the point of impact. Before moving the sight, pencil mark an index line on the sight base and rib so that sight movement can be detected.



SUGGESTED SIGHT PICTURE

Top of front sight even with top of rear sight slide. Front sight centered in notch of rear sight slide. Target bullseye centered on top of front sight.

MAGAZINE INSPECTION AND CARE

Check the magazine frequently to be certain there is adequate tension on the rotor. The rotor must move freely and have adequate tension so that each cartridge is quickly raised to the feeding position. In particular, check to be certain that the rotor tension is sufficient to correctly and firmly position the *last* (single) cartridge in the magazine.

To test the rotor tension, load one cartridge into the magazine and then firmly press against the side of the cartridge case with the tip of one of your fingers (or the eraser of a pencil). Remove your finger quickly. The cartridge should instantly and fully move into the feeding position. If it does not, the magazine should be cleaned. If cleaning does not restore proper rotor tension, *do not use the magazine.* (NOTE: After testing, remove the test cartridge.)

At the time of manufacture, proper rotor tension is set by rotating the magazine cap nut until the rotor stops turning. Then the nut is turned an additional 1 1/4 turns beyond the 'stop' position.

When cleaning is necessary to remove accumulated bullet grease, powder particles or dirt, use a non-water solvent that will not rust the metal components or adversely affect the plastic magazine box. After the magazine has been soaked in solvent to loosen foreign matter, be certain to shake it vigorously (with the loading opening away from you) to remove solvent or residue from within the magazine.

After cleaning, always check to be certain that rotor movement and tension are correct, and that no solvent or debris remain.

Do not disassemble the magazine. Improper reassembly or improper tensioning of the rotor spring can cause a potentially dangerous malfunction in the 77/22 rifle. If you experience a problem with the magazine, don't use it. Get a new one.

WARNING: If a rimfire cartridge jams while being stripped from the magazine by the bolt, it is possible for the cartridge rim to be struck and discharge the cartridge before it is fully chambered. If a cartridge discharges in the foregoing manner, the shooter and persons nearby can be seriously injured. That is why any cartridge feeding problem with a firearm is a signal to immediately stop using the firearm and determine the cause of the problem. The possibility of such an occurrence is also why shooters should wear protective glasses.

Exploded view of the 77/22 magazine components. This illustration is included to show the relationship and names of the magazine components. As noted in the text above, the magazine should not be disassembled.

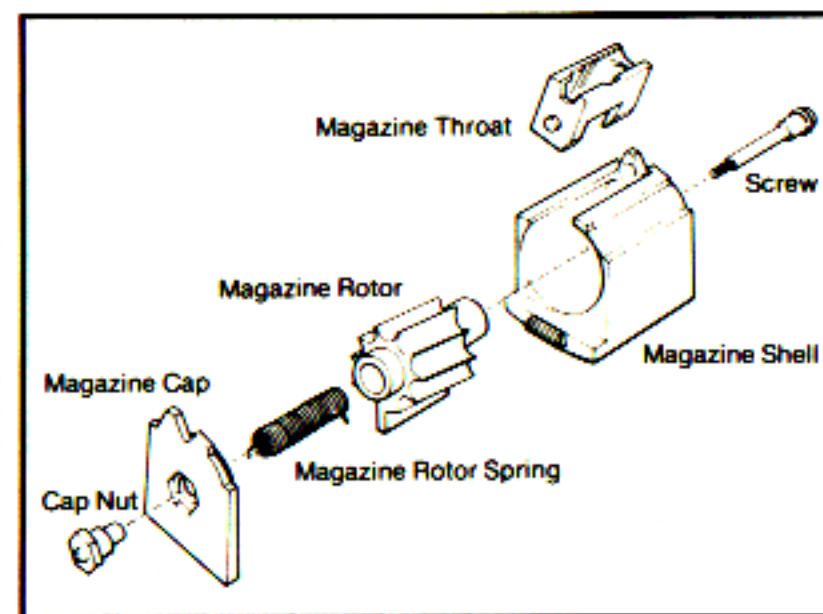

BASIC DISASSEMBLY AND REASSEMBLY

DISASSEMBLY WARNING: Never clean, lubricate, disassemble or work on a firearm while it is loaded or its magazine contains cartridges.

Although the Model 77/22 rifle can be disassembled, reassembled, and cleaned in almost any surrounding, it is preferable to carry out these procedures on a workbench or table which has a covered top. A piece of shallow nap rug or an old, coarse blanket is an ideal covering. Such a covering not only reduces the chances of the rifle slipping and being scratched, but it serves also to trap pins, plungers and springs that may otherwise get lost.

It is advisable to have a container — such as a shoe box — in which each part can be placed as it is removed from the gun.

Before attempting to disassemble the rifle for the first time, study the parts drawing and parts list so as to be familiar with the relative position, appearance and name of each part. Carry out the disassembly slowly and carefully note the position of the part *in the gun* before starting to remove it. If a part is under spring tension (as examples, the Safety Selector, Bolt Stop, Trigger), remove it cautiously and anticipate the direction the spring and plunger are most likely to 'jump'. **WARNING:** If a spring or plunger become lost do not use a substitute. Springs of correct tension are vital to the safe and reliable performance of firearms.

CAUTION: Before starting disassembly, remove sling, scope and rings and place the rear sight blade in its down (flat) position.

DISASSEMBLY:

1. Remove the magazine.
2. Check to be certain that the chamber is empty.
3. To remove the bolt: Lift the bolt handle up. Depress the bolt stop on the left side of the receiver. Remove the bolt from the rifle. (Before starting bolt disassembly, study Figure 10.)
4. **To disassemble the bolt:**
 - a. While holding the bolt (J-10), rotate the bolt sleeve (J-17) clockwise (as viewed from the rear of the rifle) to position shown in Figure 7.
 - b. Rotate the breech block (J-9) until the head of the breech block retainer (J-8) is aligned with the larger holes in the bolt. (Figure 7.)
 - c. Push out the breech block retainer by inserting a pin through the small hole on the side opposite from the larger hole. The alignment must be precise to remove the retainer. (Figure 7.)
 - d. Remove the breech block assembly by sliding it forward out of the bolt (Figure 8).
 - e. Insert a small pin (or suitable nail) into the "disassembly hole" in the cocking piece (J-13) to hold it in the rear position (Figure 8).

NOTE: The pin or nail should be as close as possible in size to the hole diameter, and at least 2 inches long so that it can be used to 'lever' the cocking piece to the rear when reassembling the bolt stop assembly into the bolt.

 - f. Unscrew the bolt sleeve (Figure 9). Remove the bolt sleeve assembly. Firing pin (J-11) can now be removed from the bolt sleeve assembly (Figure 10).

CAUTION: The bolt sleeve assembly is intended to be a permanent assembly and should not be disassembled. The parts are under great spring pressure and if disassembled could fly apart with sufficient force to cause serious injury. Also, special tools are required to correctly reassemble this part.

5. **To remove the stock: (Be certain the bolt and magazine have been removed from the rifle.)**

NOTE: On the K77/22R & RS models, disregard step b and magazine well liner in step c, below.

 - a. Remove the rear mounting screw in the trigger guard.
 - b. Swing the rear of the trigger guard out of the stock to clear trigger. Unhook trigger guard assembly from the receiver. Remove the trigger guard assembly.
 - c. Remove the front mounting screw and magazine well liner.
 - d. **VERY CAREFULLY** lift the barrel/receiver assembly from the stock.
6. **To remove the barrel:**
 - a. Remove the (2) barrel retainer screws and barrel retainer.
 - b. Slide the barrel forward to remove it from the receiver.

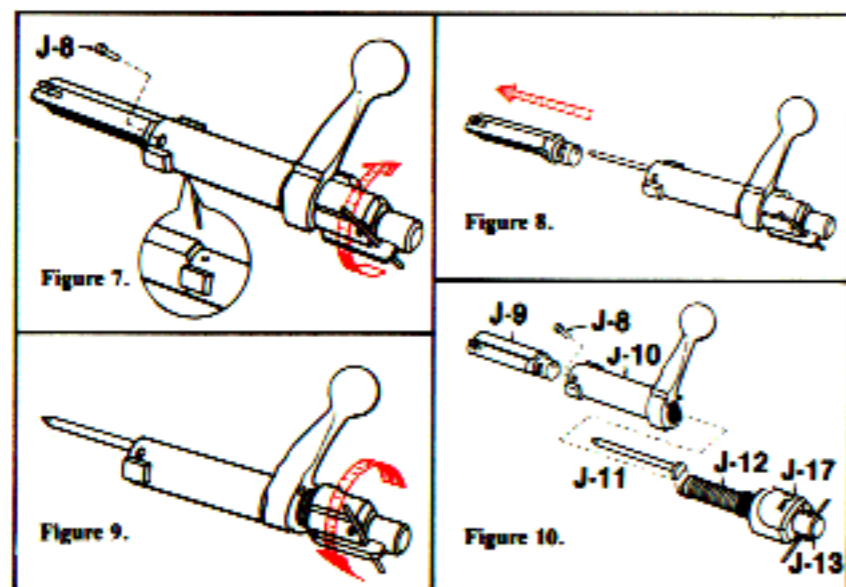

7. **To remove the trigger: (Safety Selector should be in the Fire position.)**
 - a. While holding the trigger in place, press out the trigger pivot pin. (Caution: Trigger is spring loaded.)
 - b. Remove the trigger and trigger/sear spring.
8. **To remove the sear:**
 - a. Press out the sear pivot pin.
 - b. Turn receiver upside down and slide sear forward. Sear will drop out of the top slot in the receiver.
9. **To remove safety assembly:**
 - a. Rotate the safety selector so that the upper section is positioned fully over the center of the receiver tang.
 - b. While holding the safety selector in place with thumb and forefinger, slide the retainer up out of receiver. (Caution: Safety Selector is under spring tension from a spring and plunger acting against the lower section of the safety selector. The spring and plunger will jump out if not contained.)
 - c. Lift out the safety selector.
 - d. Remove the safety selector detent and safety selector detent spring.
10. **To remove the bolt stop:**
 - a. Depress the bolt stop plunger (with the tip of a jewelers screwdriver blade or similar tool) and remove the bolt stop from the pivot. (Caution: This spring and plunger will jump out.)
 - b. Remove the bolt stop plunger and bolt stop plunger spring.

REASSEMBLY:

1. **To replace the bolt stop:**
 - a. Replace the bolt stop plunger and bolt stop plunger spring. (Be certain that the step flats on the plunger match the flats on the mating surface of the bolt stop.)
 - b. Depress the bolt stop plunger and replace the bolt stop on the pivot.
2. **To replace the safety assembly:**
 - a. Place the safety selector detent and safety selector detent spring into the hole in the receiver.
 - b. Set the safety selector in place with its upper section positioned over the center of the receiver tang.
 - c. While holding the safety selector in place with thumb and forefinger, slide the safety selector retainer into dovetail from the top. Align the notch in the safety selector retainer with the sear pivot pin hole.
3. **To replace the sear:**
 - a. Place the rear end (the end with the hole in it) of the sear into the slot from the top of the receiver. Swing the rear end of the sear up and slide the sear into position until the hole in the sear is aligned with the mating holes in the receiver.
 - b. Insert the sear pivot pin.
4. **To replace the trigger:**
 - a. Place the trigger/sear spring over the dimple in the trigger.
 - b. Assemble the trigger while aligning the spring with the dimple on the sear.
 - c. While holding the trigger in position, replace the trigger pivot pin.
5. **To replace the barrel:**
 - a. Assemble the barrel into the receiver assembly.
 - b. Replace the barrel retainer and barrel retainer screws.
6. **To replace the barrel/receiver assembly into the stock: (Caution: Be certain that pivot pins are not protruding from either side of the receiver.)**

NOTE: On the K77/22R & RS models, disregard magazine well liner installation in step B, and all of steps c & d, below.

 - a. Carefully install the barrel/receiver assembly into the stock, making sure the barrel/receiver assembly is in the most rearward position.
 - b. Install the magazine well liner and front mounting screw.
 - c. Hook the forward end of the trigger guard assembly into the receiver.
 - d. Swing the rear of the trigger guard into position.
 - e. Install the rear mounting screw.

7. To assemble the bolt:

- a. Place the firing pin into the mating slot in bolt sleeve assembly.
- b. Slide the bolt sleeve assembly into the bolt from the rear.
- c. Screw the bolt sleeve into the bolt to position shown.
- d. Install the breech block into the front end of the bolt.
- e. Align the holes in the breech block with the hole in the bolt.
- f. Replace the breech block retainer. Flats on the breech block retainer must be aligned with the slot in the breech block when the retainer is installed.
- g. Rotate the bolt sleeve assembly in counter-clockwise position until the cocking piece engages *small notch* in the bolt.
- h. Remove the pin or nail from the cocking piece. If the breech block (J-9) does not rotate freely about 1/16" in both direction, then reinsert the pin or nail in the cocking piece hole and check to be certain that the breech block retainer (J-8) is fully seated. Only when the bolt is correctly assembled should it be inserted into the receiver.
- i. Insert the bolt into the receiver.

REGARDING ACCURACY: If your rifle is not as 'accurate' as you believe it should be, before concluding that some serious fault exists, run the following checks: (1) Be certain the front mounting screw (J-47) and the rear mounting screw (J-48) are snugly tightened. (2) Be certain the bore is clean and free from accumulated fouling (deposited by powder and lead bullets). See the cleaning section of this Manual. (3) Check the sights, or scope mounting system, for tightness, setting and alignment. (4) Be certain the two barrel retainer screws (J-51) are fully tightened.

If everything is tight, the bore is clean and the sights OK, and the accuracy problem persists, *DO NOT alter the stock bedding in any way.* Do not scrape away wood, and do not bed with 'glass', plastic, epoxy, etc. Once a rifle stock has been altered, it cannot be reworked by our Service Department. If you have an accuracy problem, write a brief letter to the Service Department (Newport, N.H. 03773) and describe the nature of the problem.

You will receive a prompt response from us and, if indicated, detailed instructions with regard to the return of the rifle.

NOTE: The accuracy of any rimfire rifle can vary depending upon the make and type of Long Rifle cartridges used in it. Such being the case, if your model 77/22 rifle does not perform to expectations, it is advisable to try several brands and types of cartridges to determine which ones deliver the best accuracy.

CARE AND CLEANING

Before cleaning, be certain the rifle and its magazine contain no cartridges.

A firearm must be free of rust, dirt, grease and firing residues to function safely and reliably. Periodic maintenance, which includes inspection of components to determine if they are in proper working order, is absolutely essential.

The popular .22 rimfire cartridge deposits particles of bullet lubricant and powder on the bore, chamber, bolt, receiver, magazine, and other parts of the rifle. Therefore, the frequency and extent of required cleaning is directly related to how much the rifle is fired. There is no fixed rule as to how frequently the cleaning should be carried out, but the alert gun owner soon learns that any firearm functions most reliably when it is free of accumulations of grease and other firing residues.

Basic cleaning equipment includes: A correct size Cleaning Rod equipped with Bore Brushes (fiber and brass) and a Tip in which a cloth patch can be inserted, Patches, Powder Solvent, Lubricant, Small lint-free Cloths and a Toothbrush.

Some hints for effective use of the equipment: Use correct size—22 caliber—patches and brushes. Larger sizes will bind in the bore and can be very difficult to remove! Insert rod from the chamber end of the barrel and push firmly so the patch or brush emerges from the muzzle. Don't reverse the rod when a brush or patch is being used—it may bind. Don't use patches or brushes dripping with solvent or oil. Wet them, and squeeze out excess before using. Use rod and brushes with care so as not to damage gun. In particular, the cleaning rod and other items that pass thru the bore should be free of any abrasive substance that might 'bell' the muzzle or scar the rifling.

1. To clean the rifle thoroughly, disassemble to the extent described elsewhere in this manual, taking care to put pins and similar easily mislaid and 'rolling' components in a tray.

2. Push-pull a solvent-wetted patch through the bore several times. Next, using a solvent-wetted brush, run it the full length of the bore as many times as is necessary to completely remove all foreign matter from the bore and chamber. Dry the bore with clean patches and examine it. If bore remains fouled, repeat the brushing *because leading can reduce accuracy and grease can interfere with proper chambering of the cartridge.* Complete the cleaning by dry-patch wiping of bore and chamber.

3. Use a clean, solvent-wetted patch to remove firing residue and dirt from all components and 'reachable' surfaces inside the receiver. Use the solvent-wetted toothbrush to dislodge caked dirt from all parts of the bolt assembly and from surfaces inside the receiver that can't be reached with a patch. Use cleaning patches or the cloth to remove the solvent.

4. Wipe all surfaces—internal and external—with oil-wetted patch or cloth that will deposit a very light and sparing coat of oil. Oil and similar preparations 'collect' dirt particles which can interfere with reliable functioning of the rifle. Therefore, use these preparations very sparingly. A very sparing drop of oil applied to the bolt assembly components, the pivot points of the trigger mechanism as well as the safety, the bolt stop and the magazine latch, will work into all the parts that need lubrication.

5. Reassemble the rifle and carefully wipe all solvent, lubricating and preservative preparations from the stock.

6. If the rifle is to be stored for an extended period, rewipe all external surfaces with the cloth containing the oil or preservative.

CAUTION: Do not store the rifle in a leather case or scabbard. Leather attracts moisture, even though it may appear to be dry.

WARNING: Never store a firearm in such a manner that it may unintentionally be dislodged. A firearm should be stored securely and unloaded.

MAINTENANCE OF STAINLESS STEEL RIFLES:

Firearms and components made of stainless steel are more resistant to corrosion than those of blued steel. However, in the interest of proper operation and long life of a stainless steel firearm inspect it frequently and clean, lubricate and apply an appropriate rust preventative.

Sometimes discoloration occurs from perspiration or from contact with some types of gun cases. Rusting may occur as a result of the firearm being exposed to moisture, salt air or chemicals.

Minor discoloration can usually be removed by rubbing the stained area with an abrasive ink eraser, crocus cloth, or a "metal polishing" compound. When using any of these abrasives, proceed with care and use light pressure to achieve a blending of 'color' with those areas that are not discolored.

External surfaces most subject to rusting from handling, or from exposure to the elements should be cleaned and wiped dry after use or after exposure to adverse conditions. If the rifle is to be stored, coat it with a light film of oil or preservative. Where the rifle is in continuing use, and the presence of oil or grease would be objectionable, then the external surfaces can be coated (after cleaning and drying) with a paste wax formulated for use on metals. Apply the wax sparingly, allow time for it to dry hard, then buff lightly with a soft cloth. When applying the wax, take care that it does not get into the mechanism or on the functioning parts or in the bore.

LUBRICATION WARNING

Firing a rifle with oil, grease, or any other material even partially obstructing the bore may result in damage to the rifle and injury to the shooter and those nearby.

Do *not* spray or apply lubricants directly on ammunition. If the powder charge of a cartridge is affected by the lubricant, it may not be ignited, but the energy from the primer may be sufficient to push the bullet into the bore where it may become lodged. Firing a subsequent bullet into the obstructed bore may damage the rifle and cause injury to the shooter and those nearby. *Use lubricants properly.* You are responsible for the proper care and maintenance of your firearm.

SERVICE AND PARTS POLICY

If you have any question with regard to the performance of your model 77/22 rifle please write to our Newport, N.H. Service Department, fully describing all circumstances and conditions involved.

If you should return your 77/22 to the factory for repair, or order parts for it, please comply with the following suggestions for prompt service:

SHIPPING FIREARMS FOR REPAIR:

Ruger 77/22 rifles returned to the factory for repair should be sent to: Sturm, Ruger & Co., Inc., Service Department, Newport, N.H. 03773. Phone: (603)-863-3300.

Guns should be sent prepaid. *We will not accept collect shipments.*
The Federal Gun Control Act, as well as the laws of most States and localities, does not prohibit an individual (who is not otherwise barred from purchasing or possessing a firearm) from shipping a firearm directly to the manufacturer for repair. However, before you ship your rifle to us, be certain that your State or locality does not have a law or regulation which will prohibit you from receiving the rifle from us after it has been repaired. If such receiving is prohibited, then please have a Federally Licensed firearms dealer ship the gun to us. If your rifle is sent to us by a dealer, it will be returned to him after being repaired. If a handgun (pistol or revolver) is shipped by an individual who does not hold a Federal Firearms License, it *must* be shipped via UPS. Persons who do not hold a Federal Firearms License are prohibited by Federal law from shipping a handgun by Mail. Handguns mailed in violation of the law are impounded by the Post Office.

Please do *not* include rifle case, sling, telescopic sight, or custom accessories with a firearm being shipped to the factory for service. Rifles and shotguns may be shipped via Parcel Post. Always insure your shipment.

Enclose a letter which includes your name, address, telephone number, and serial number and model of the firearm. Describe in detail the trouble you have experienced with your firearm, or the work you wish to have done. Merely stating that the firearm 'needs repair' is inadequate information.

We do not refinish stocks.
Work performed will bear a net minimum labor charge of \$10.00 plus a \$5.00 shipping and handling charge. The charge for rebluing the 77/22 rifle is \$35.00 which includes labor. Custom gunsmithing service or non-standard alterations are NOT AVAILABLE from Ruger Service Departments.

WARNING: Before shipping any firearm, be absolutely certain that it and its magazine are unloaded. Do not ship cartridges with a firearm.

ORDERING PARTS:

All parts orders should be sent to: Sturm, Ruger & Co., Inc., Service Department, Newport, N.H. 03773. Phone: (603)-863-3300.

Payment in the form of a check or money order must accompany the parts order. We cannot comply with open account, credit cards or C.O.D. requests. Minimum parts order is \$1.00 plus \$1.50 shipping and handling charge.

Order parts by Part Number and Part Name and *include the entire serial number of the firearm* for which the parts are being ordered.

The price shown for parts does not include the *minimum* net labor charge of \$10.00 plus a \$5.00 shipping and handling charge for parts that are factory fit. All factory fitted parts are fitted *on an exchange basis only*. We will not return the replaced parts. *Parts that must be factory fitted are shown in the parts list preceded by an asterisk.

WARNING TO PARTS PURCHASERS

It is the purchaser's responsibility to be absolutely certain that any parts ordered from the factory are correctly fitted and installed. Firearms are complicated mechanisms and IMPROPER FITTING OF PARTS MAY RESULT IN A DANGEROUS MALFUNCTION, DAMAGE TO THE FIREARM, AND INJURY TO THE SHOOTER AND OTHER PERSONS. The purchaser and installer of parts must accept full responsibility for the correct adjustment and functioning of the firearm after such installation.

PARTS LIST AND SUGGESTED RETAIL PRICES

Part No.	Part Name	Blued	Stainless
J-3	*Barrel (with sights)	\$ 39.25	\$55.00
J-3A	*Barrel (without sights)	31.25	47.00
J00304	*Barrel (with sights) .22 WMR only	39.25	55.00
J00305	*Barrel (without sights) .22 WMR only	31.25	47.00
B-66	Barrel Retainer (V-Block)	1.25	—
J-51	Barrel Retainer Screw (2)	per pair .50	—
J-10	*Bolt	20.50	25.00
J21002	*Bolt .22 WMR only	20.50	25.00
J-26	Bolt Lock Plunger	1.25	1.50
J-46	Bolt Lock Plunger Retainer	.50	—
J-45	Bolt Lock Plunger Spring	.50	—
J-17	Bolt Sleeve	9.00	12.00
J-53	Bolt Stop	3.50	3.75
J-52	Bolt Stop Plunger	.50	—
J-54	Bolt Stop Plunger Spring	.50	—
J-9	*Breech Block	22.00	—
J00901	*Breech Block .22 WMR only	22.00	—
J-8	Breech Block Retainer	.50	—
B-90	Butt Plate	2.50	—
B-91	Butt Plate Screw (2)	per pair .50	—
J-15	Cartridge Support	.50	.75
J-7	Cartridge Support Spring	.50	—
J-14	Extractor	.50	.75
J-16	Extractor Plunger/Cartridge Support Plunger	.50	.50
J-19	Extractor Spring	.50	—
J-11	Firing Pin	2.50	—
J-47	Front Mounting Screw	.50	1.50
J-60	Front Sight	3.00	—
JX-1	Magazine Complete	8.20	—
J22701	Magazine Complete .22 WMR only	8.20	—
J-34	Magazine Latch	1.25	—
J-88	Magazine Latch Block Retainer	.50	—
J-35	Magazine Latch Pivot Pin	.50	—
J-40	Magazine Latch Plunger	.50	—
B-37	Magazine Latch Plunger Spring	.50	—
J-6	Magazine Well Liner	3.75	—
D-80	Pistol Grip Cap	.75	—
C-107	Pistol Grip Cap Medallion	.50	—
C-96	Pistol Grip Cap Screw	.50	—
J-48	Rear Mounting Screw	.50	1.50
J-61	Rear Sight	5.00	—
J-1	*Receiver	Not Sold Separately	—
J-38	*Safety Selector	2.75	4.00
J-43	Safety Selector Detent	.50	—
J-44	Safety Selector Detent Spring	.50	—
J-21	Safety Selector Retainer	.50	2.00
D-74	Scope Ring Clamp	1.00	—
D-73	Scope Ring Nut	.75	—
D-76	Scope Ring Screw (Set of eight)	1.00	—
S-100R	Scope ring assembly, standard height, set of two	33.60	—
KD-71	Scope ring assembly, standard height, set of two	—	42.90
J-23	*Sear	2.25	—
J-42	Sear Pivot Pin	.50	—
D-86	Sling Swivel Front Screw with Nut	1.75	—
D-87	Sling Swivel Rear Mounting Stud	.75	—
J-4	Stock	106.00	—
J-49	Striker Cross Pin/Trigger Pivot Pin	.50	—
J-12	Striker Spring	.50	—
J-13	Striker/Cocking Piece Assembly (sold as assy. only)	10.75	12.00
J-20	*Trigger	4.50	—
J-2	Trigger Guard Assembly	7.25	—
J30201	Trigger Guard Assembly .22 WMR only	7.25	—
J-24	Trigger/Sear Spring	.50	—

*Parts so marked must be factory fitted.

Design, specifications and prices are subject to change without notice.

NOTE: Not all parts are manufactured in both Stainless steel and Blued steel versions. If a part shows a price under both Blued and Stainless columns then the part is made in Blued and Stainless. You must order the version of the part which is the same as your firearm — Blued or Stainless. When ordering Stainless parts use a K prefix before the part number.

PARTS LISTING FOR STAINLESS STEEL MODEL WITH SYNTHETIC STOCK

Part No.	Part Name	Blued Stainless	
B-51	Escutcheon, 2 required, not illustrated	\$.50	\$ —
W01015	Ferrule, left side, 3 required	—	.50
W01014	Ferrule, right side, 3 required	—	.50
J00425	Forearm insert, left hand, plastic	—	1.50
J00424	Forearm insert, right hand, plastic	—	1.50
KJ04701	Front mounting screw	—	1.50
KJ00420	Front sling swivel	—	1.00
KJ00422	Front swivel pin	—	.50
KJ00416	Insert screw, plastic rear	—	1.25
KJ00415	Insert screw, plastic, front	—	1.25
KJ03501	Magazine latch pivot pin	—	2.00
KW01300	Pistol grip insert screw	—	1.25
KW01300	Pistol grip insert screw, plastic	—	1.25
J00419	Pistol grip insert, left hand, plastic	—	1.00
J00418	Pistol grip insert, right hand, plastic	—	1.00
KJ04802	Rear mounting screw	—	1.50
KJ00421	Rear sling swivel	—	1.00
KJ00423	Rear swivel pin	—	.50
J05602	Recoil pad	2.50	—
J00402	Stock	55.00	—

NOTE: The synthetic style stock used on the Stainless Steel 77/22 ONLY fits the Stainless steel model. Neither the stock nor its fittings are interchangeable with corresponding parts of the blued 77/22 model.

THE BASIC RULES OF SAFE FIREARMS HANDLING

We believe that Americans have a right to purchase and use firearms for lawful purposes. The private ownership of firearms in America is traditional, but that ownership imposes the *responsibility* on the gun owner to use his firearms in a way which will ensure his own safety and that of others. When firearms are used in a safe and responsible manner, they are a great source of pleasure and satisfaction, and represent a fundamental part of our personal liberty.

Firearms do not cause accidents! Firearms accidents are almost always found to have been the result of carelessness, or ignorance on the part of the shooter of the basic rules of safe gun handling.

The following rules must be observed by gun users at all times. Safe gun handling is not just desirable, it is absolutely essential to the continuation of gun ownership and sport shooting as we know it today.

1. LEARN THE MECHANICAL AND HANDLING CHARACTERISTICS OF THE FIREARM YOU ARE USING. Not all firearms are the same. The method of carrying and handling firearms varies in accordance with the mechanical provisions for avoiding accidental discharge and the various proper procedures for loading and unloading. No person should handle any firearm without *first* having thoroughly familiarized himself with the particular type of firearm he is using, and with safe gun handling in general.

2. ALWAYS KEEP THE MUZZLE POINTED IN A SAFE DIRECTION. Be sure of the bullet stop behind your target, even when dry-firing. Never let the muzzle of a firearm point at any part of your body or at another person. This is particularly important when loading or unloading a firearm. In the event of an accidental discharge, no injury can occur as long as the muzzle is pointing in a safe direction. A safe direction means a direction which will not permit a discharged bullet to strike a person, or to strike an object from which the bullet may ricochet. A safe direction must take into account the fact that a bullet may penetrate a wall, ceiling, floor, window, etc., and strike a person or damage property. Make it a habit to know exactly where the muzzle of your gun is pointing whenever you handle it, and be sure that you are always in control of the direction in which the muzzle is pointing, even if you fall or stumble.

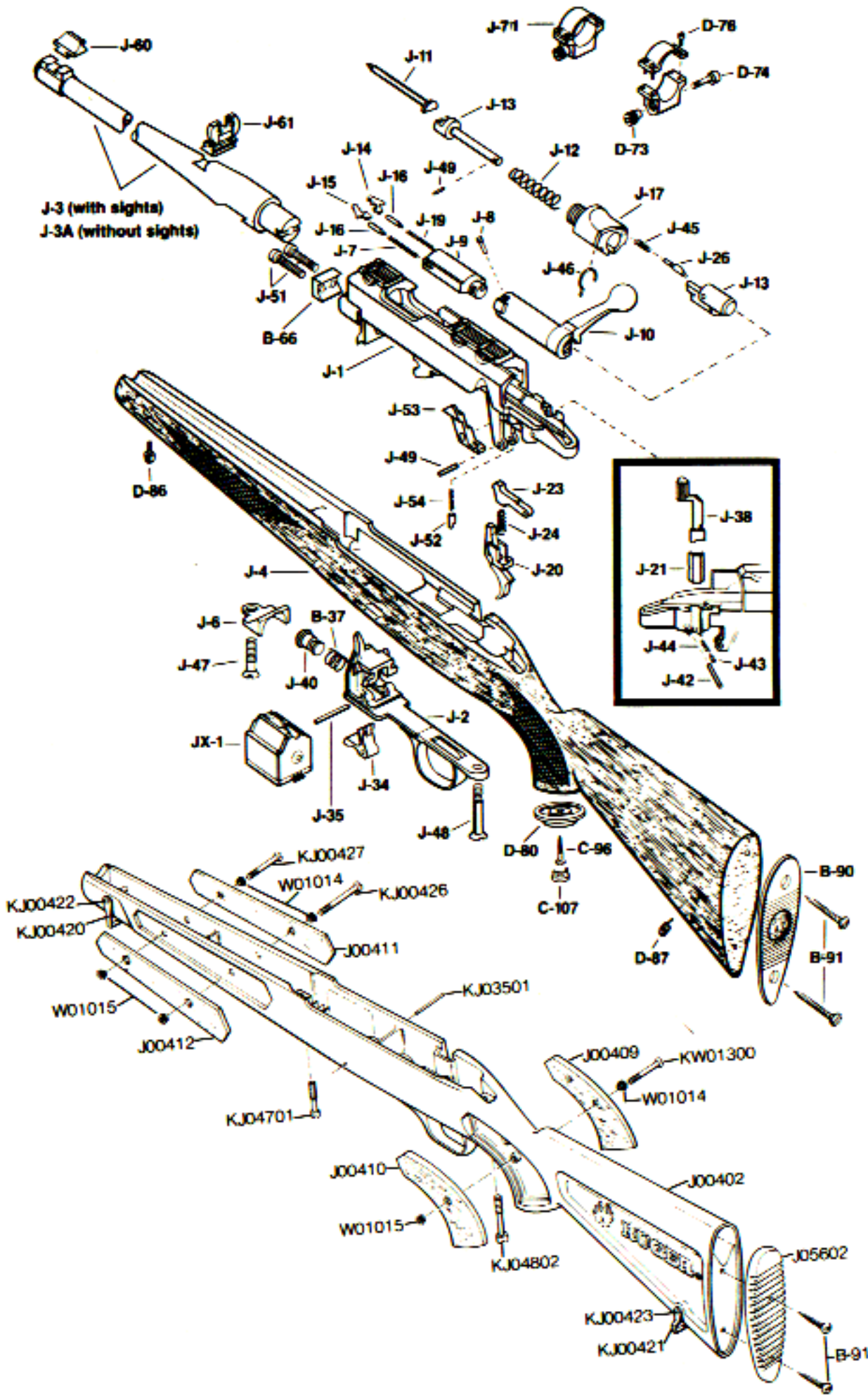

Firearms users are cautioned that a gun containing modified, broken, malfunctioning, or badly worn parts should not be fired!

3. FIREARMS SHOULD BE UNLOADED WHEN NOT IN USE. Firearms should be loaded only when you are in the field or on the target range or shooting area, ready to shoot. Firearms and ammunition should be securely locked in racks or cabinets when not in use. Ammunition should be safely stored *separate* from firearms. Store your firearms out of sight of visitors and children. It is the gun owner's *responsibility* to be certain that children and persons unfamiliar with firearms cannot gain access to firearms or ammunition.

4. BE SURE THE BARREL IS CLEAR OF OBSTRUCTIONS BEFORE SHOOTING. Even a bit of mud, snow or excess lubricating oil or grease in the bore may cause the barrel to bulge, or even burst on firing, and can cause injury to the shooter and bystanders. Be sure that you are using ammunition of the proper caliber and loading for the gun you are using. If the report or recoil on firing seems weak, or doesn't seem quite right, **CEASE FIRING IMMEDIATELY** and check to be sure that no obstruction has become lodged in the barrel.

5. BE SURE OF YOUR TARGET BEFORE YOU SHOOT. Don't shoot unless you know exactly where your bullet is going to strike. Be sure of the bullet stop behind your target, even when dry-firing with an unloaded gun. If you are in the field hunting, do *not* fire at a movement or noise. Take the time to be *absolutely certain* of your target before you pull the trigger.

6. WEAR SHOOTING GLASSES AND HEARING PROTECTORS WHEN YOU SHOOT. All shooters should wear protective shooting glasses and some form of hearing protectors when shooting. Exposure to shooting noise can damage hearing, and adequate vision protection when shooting is essential.

7. NEVER CLIMB A TREE OR FENCE WITH A LOADED FIREARM. Put the firearm down carefully before climbing a fence, and *unload* it before climbing or descending a tree or jumping over a ditch or other obstruction. Never pull or push a loaded firearm toward yourself or another person. When in doubt, unload your gun!

8. DON'T SHOOT AT A HARD SURFACE, OR AT WATER. Bullets can glance off many surfaces like rocks or the surface of water and travel in unpredictable directions with considerable velocity.

9. NEVER TRANSPORT A LOADED FIREARM. Firearms should always be unloaded before being placed in a vehicle. A suitable carrying case or scabbard should be used to carry a firearm to and from the shooting area.

10. AVOID ALCOHOLIC BEVERAGES WHEN SHOOTING. Don't drink until the day's shooting is over. Handling firearms while under the influence of alcohol in any form constitutes a criminal disregard for the safety of others.

WHY NO WARRANTY CARD HAS BEEN PACKED WITH THIS NEW RUGER FIREARM

The Magnuson-Moss (Public Law 93-637) does not require any seller or manufacturer of a consumer product to give a written warranty. It does provide that if a written warranty is given, it must be designated as "limited" or as "full" and sets minimum standards for a "full" warranty.

Sturm, Ruger & Company, Inc. has elected not to provide any written warranty either "limited" or "full", rather than to attempt to comply with the provisions of the Magnuson-Moss Act and the regulations issued thereunder.

There are certain implied warranties under state law with respect to sales of consumer goods. As the extent and interpretation of these implied warranties varies from state to state, you should refer to your state statutes.

Sturm, Ruger & Company wishes to assure its customers of its continued interest in providing service to owners of Ruger firearms.

A COPY OF THE INSTRUCTION MANUAL FOR EACH MODEL RUGER FIREARM IS AVAILABLE FROM THE FACTORY ON REQUEST. THESE INSTRUCTION MANUALS CONTAIN IMPORTANT WARNINGS WHICH MUST BE UNDERSTOOD BEFORE USING THESE FIREARMS.